

---

# **SINGLE PHASE MOTORS**

## **INSTALLATION AND MAINTENANCE MANUAL**

March 21, 2006

**Irvine, California (800) 474-0520**  
**Indianapolis, Indiana (800) 866-7973**  
**Hamilton, Ontario (800) 809-0330**

**e-mail: [sales@sterlingelectric.com](mailto:sales@sterlingelectric.com)**

**[www.sterlingelectric.com](http://www.sterlingelectric.com)**

## INSTRUCTION MANUAL CAPACITOR START SINGLE PHASE MOTORS

### DANGER

ONLY QUALIFIED ELECTRICAL PERSONNEL FAMILIAR WITH THE CONSTRUCTION AND OPERATION OF THE EQUIPMENT AND THE HAZARDS INVOLVED SHOULD INSTALL, ADJUST, OPERATE, AND/OR SERVICE THIS EQUIPMENT. READ AND UNDERSTAND THIS MANUAL IN ITS ENTIRETY BEFORE PROCEEDING. FAILURE TO OBSERVE THIS CAUTION RESULT IN SEVERE BODILY INJURY OR LOSS OF LIFE.

Read ALL instructions prior to operating motor

Buyer shall be solely responsible for determining the adequacy of the product for any and all uses to which buyer shall apply the product. The application by buyer shall not be subject to any implied warranty of fitness for a particular purpose. Information contained in this manual is considered correct at the time of publication and is subject to change without notice.

### SAFETY ALERT

**WARNING:** Make certain that the power supply is disconnected before attempting to service or remove any components. Lock out the power supply and tag it to prevent unexpected application of power.

**CAUTION:** The system of connected rotating parts must be free from critical speed, torsional or other type vibration, no matter how induced. The responsibility for this system analysis lies with the purchaser.

**CAUTION:** Test run unit to verify operation. If the unit tested is a prototype, that unit must be of current production.

### RECEIVING

- (1) Check nameplate data.
- (2) Check whether any damage has occurred during transportation. If there is evidence of rough handling or potential damage in shipment, file a claim immediately with the carrier. Notify your Sterling Electric sales representative.
- (3) Turn motor shaft by hand to check that it turns freely.

### LOCATION

- (1) Totally enclosed motors may be installed where dirt, moisture and corrosion are present, or in outdoor locations. Specially designed washdown duty motors can be used in sanitary environments where exposure to high pressure wash down procedures are present.

**WARNING:** Installation instructions regarding the use of washdown duty motors and the location and installation of condensation drain plugs as supplied with the motor must be followed or the warranty will be void. Consult factory for further information.

## MOUNTING

- (1) Mount motor securely on a firm, flat base. All ball bearing motors, horizontal or vertical, normal thrust, grease lubricated, may be mounted in any position.
- (2) Align motor accurately, using a flexible coupling if possible. For drive recommendations, consult with drive or equipment manufacturer, or Sterling Electric.
- (3) V-Belt Sheave Pitch Diameters should not be less than the NEMA recommended values. Refer to NEMA MG1-14.41.
- (4) Tighten belts only enough to prevent belt slippage. Belt speed should not exceed 5000 feet per minute.

## POWER SUPPLY AND CONNECTIONS

- (1) Nameplate voltage and frequency should agree with power supply. Motor will operate satisfactorily on line voltage within 10% of nameplate value; or frequency within 5%; combined variation not to exceed 10%. 230 volt motors can be used on 208 volt network systems, but with slightly modified performance characteristics.
- (2) Dual voltage motors can be connected for the desired voltage by following the connection diagram on the nameplate.
- (3) Wiring of motor and motor control, overload protection and grounding should be in accordance with the National Electric Code and/or local building codes. Consult wiring diagrams below. Motors with 6 leads do not contain auto-reset thermal protection. Motors with 7 leads contain auto-reset thermal protection.

6 LEAD 1 PHASE

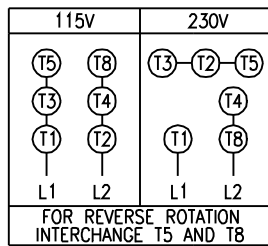

7 LEAD 1 PHASE

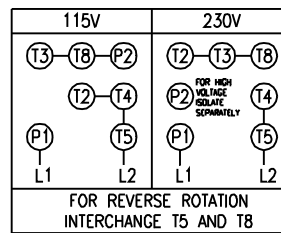

## START UP

- (1) Dry the motor windings if motor has been stored in a damp location. In drying, DO NOT exceed 194 degrees F (90 degrees C).
- (2) Disconnect load and start motor. Check direction of rotation. Consult connection diagram on motor nameplate to change direction of rotation on bi-directional motors.
- (3) Connect motor to load. The motor should start up quickly and run smoothly. If not, shut power off at once. Recheck the assembly including all connections before restarting. Operate under load for at least one hour. Observe whether any unusual noise or heating has developed and check operating current against nameplate data.
- (4) If excessive vibration is noted, check for loose mounting bolts, too flexible motor support structure, or transmitted vibration from adjacent machinery. Recheck the coupling alignment between the motor and the driven equipment.

**NOTE:** Sterling Electric single phase capacitor start motors utilize a mechanical centrifugal switching mechanism to engage and disengage the start winding. This switching mechanism may be heard engaging when the motor is shut off and the shaft is spinning down. This is considered normal operation.

## MAINTENANCE

- (1) **INSPECTION:** Inspect motor at regular intervals. Keep motor clean and ventilating openings clear of any obstructions.
- (2) **LUBRICATION:** Pre-lubricated double sealed bearings and shielded bearings are lubricated for life and do not need to be re-lubricated. The bearings may be changed if necessary. Bearing sizes are noted on the nameplate. See table for standard bearing sizes for 56C and 140T motors.

Frame Size	Standard Duty		Washdown Duty	
	DE	ODE	DE	ODE
56C / 140TC	6205ZZ	6204ZZ	6205LL	6204LL

## RENEWAL PARTS

- (1) Use only genuine Sterling replacement parts.
- (2) When ordering, include model number, serial number, item number and description (from parts list), and quantity required.

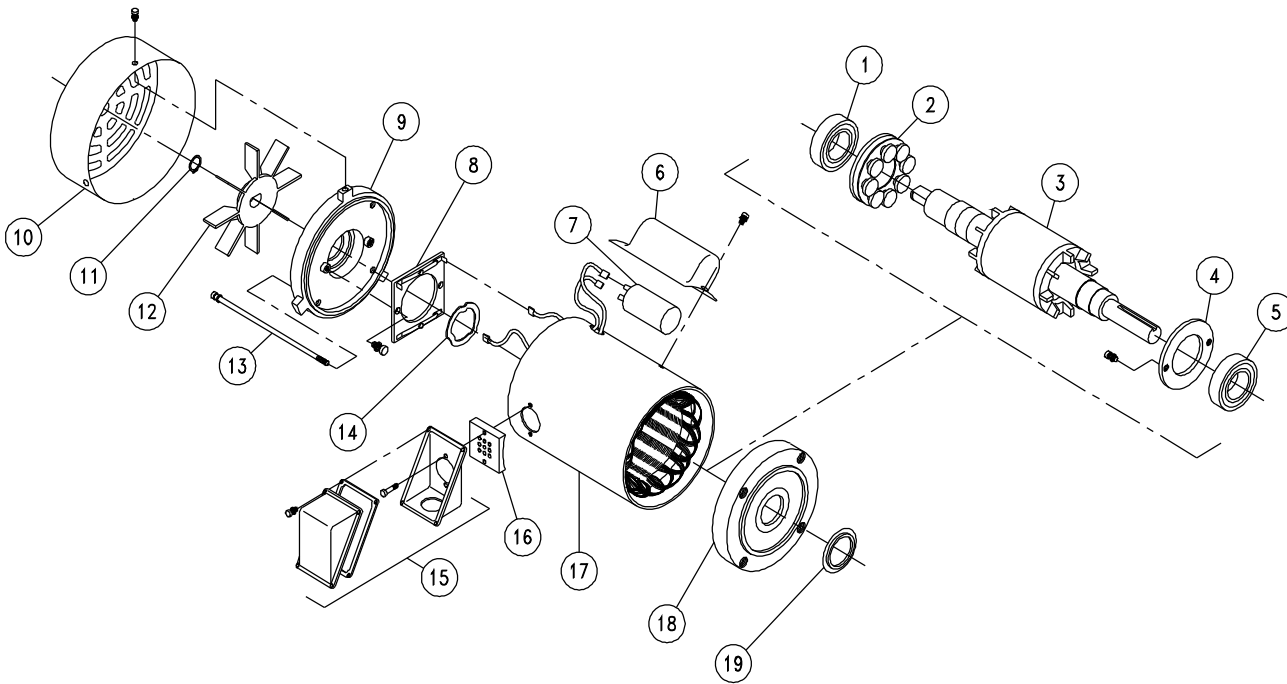

## Parts List

Item No.	Description	Qty	Item No.	Description	Qty
1	ODE Ball Bearing	1	11	External Snap Ring*	1
2	Centrifugal Mechanism	1	12	Outside Fan*	1
3	Shaft / Rotor Assembly	1	13	Thru-Bolt	1
4	Bearing Cap	1	14	Wave Washer	1
5	DE Ball Bearing	1	15	Terminal Box Assembly	1
6	Capacitor Cover	1	16	Lead Seal	1
7	Start Capacitor	1	17	Frame / Stator Assembly	1
8	Stationary Switch	1	18	DE Bracket	1
9	ODE Bracket	1	19	Slinger	1
10	Fan Cover*	1			

\* TEFC Models Only

## IMPORTANT INFORMATION

In the event of the resale of any of the goods, in whatever form, Resellers/Buyers will include the following language in a conspicuous place and in a conspicuous manner in a written agreement covering such sale:

*The manufacturer makes no warranty or representations, expressed or implied, by operation of law or otherwise, as to the merchantability or fitness for a particular purpose of the good sold hereunder. Buyer acknowledges that it alone has determined that the goods purchased hereunder will suitably meet the requirements of their intended use. In no event will manufacturer be liable for consequential, incidental or other damages.*

Resellers/Buyers agree to also include this entire document including the warnings above in a conspicuous place and in a conspicuous manner in writing to instruct users on the safe usage of the product.

This instruction manual should be read together with all other printed information such as catalogs, supplied by Sterling Electric.

## TROUBLESHOOTING

TROUBLE SHOOTER'S GUIDE BASED ON SYMPTOMS

SYMPTOMS	CAUSE	RESULT	REMEDY
1. Motor does not start.	a. Incorrectly connected.	a. Burnout	a. Connect correctly per diagram on motor.
	b. Incorrect power supply.	b. Burnout	b. Use only with correct rated power supply.
	c. Fuse out, loose or open connection.	c. Burnout	c. Correct open circuit condition.
	d. Open control circuit.	d. None	d. Correct open circuit condition.
	e. Rotating parts of motor may be jammed mechanically.	e. Burnout	e. Check and correct: 1. Bent shaft 2. Broken housing 3. Damaged bearing 4. Jammed or broken fan 5. Foreign material in motor
	f. Driven machine may be jammed.	f. Burnout	f. Correct jammed condition.
	g. No power supply.	g. None	g. Check voltage at motor and work back to power supply.
	h. Faulty Capacitor	h. Burnout	h. Replace capacitor
2. Motor starts, but does not come up to speed.	a. Same as 1-a, b, c above.		
	b. Overload	b. Burnout	b. Reduce load to bring current to rated limit. Use proper fuses and overload protection.
3. Motor noisy electrically	a. Same as 1-a, b, c above.		

SYMPTOMS	CAUSE	RESULT	REMEDY
4. Motor runs hot. Exceeds rating.	a. Same as 1-a, b, c above.		
	b. Overload	b. Burnout	b. Reduce load.
	c. Impaired ventilation.	c. Burnout	c. Remove obstruction.
	d. Frequent start or stop.	d. Burnout	d. 1. Reduce number of starts or reversals. 2. Secure proper motor for this duty.
	e. Imbalance in voltage or frequency of power supply.	e. Burnout	e. Check and correct power supply.
5. Motor noisy mechanically	a. Misalignment of coupling or sprocket.	a. Bearing failure, broken shaft, burnout due to rotor drag.	a. Correct misalignment.
	b. Mechanical unbalance of rotating parts.	b. Same as 5-a	b. Find unbalanced part, then rebalance.
	c. Lack of or improper lubricant.	c. Bearing failure	c. Use correct lubricant, and replace parts as necessary.
	d. Foreign material in lubricant.	d. Same as 5-c	d. Clean out or replace bearing.
	e. Overload	e. Same as 5-c	e. Remove overload condition. Replace damaged parts.
	f. Shock load.	f. Same as 5-c	f. Correct causes and replace damaged parts.
	g. Mounting acts as amplifier of normal noise.	g. Annoying	g. Isolate motor from base.
	h. Rotor dragging due to worn bearings, shaft or bracket	h. Burnout	h. Replace bearings, shaft or bracket as needed.
6. Bearing failure	a. Same as 5-a, b, c, d, e above.	a. Burnout, damaged shaft or housing	a. Replace bearings and follow 5-a, b, c, d, e above.
	b. Entry of water or foreign material into bearing housing.	b. Same as 6-a above	b. Replace bearings and shield against entry of foreign material (water, dust, etc.) Use proper motor.

#### TYPICAL BURNOUT PATTERNS

SYMPTOM	CAUSED BY	APPEARANCE
1. Shorted coil	a. Moisture, chemicals, foreign material in motor, damage winding.	a. Black or burned coil with remainder of winding good.
	b. Faulty stationary switch	b. Black or burned coil with remainder of winding good. Burned contacts on stationary switch
2. 100% Burnout	a. Overload.	a. Burned equally all around winding.
	b. Stalled.	b. Burned equally all around winding.
	c. Impaired ventilation.	c. Burned equally all around winding.
	d. Frequent reversal or starting.	d. Burned equally all around winding.
	e. Incorrect power.	e. Burned equally all around winding.
3. Other	a. Improper connection.	a. Irregular burned groups or spot burns.
	b. Ground	b. Badly damaged burn spot.

### WARRANTY (LIMITED)

The warranty will cover all of the parts in the motor for 24 months from the date of shipment.

The warranty is only for parts and labor. In no event shall our liability exceed the original price of the unit, nor does it cover cost of on site repair, installation, or freight.

Contact the service department for a complete explanation as to the full warranty policies and conditions of sale.

All dimensions designs and specifications are subject to change without notice.

**The information in this user's manual is subject to change without notice.**